

35VX³



Durability

NEW

Warranted, highly durable rubber shoe comes as standard equipment

Like no others in the industry, the rubber shoe is warranted for either 2 years or 1,500 hours against steel cord cut-off.

* See Page 27 for details.



New castle-nut design reduces horizontal tolerance

NEW



The arm-end and boom-arm joint are fixed with castle nuts. The reduction of horizontal tolerance is achieved.

* See Page 27 for details.

Highly durable blades made even stronger

Embedded boom center working lights

Bucket cylinder hose built inside the arm



* See Page 27 for details.

Durable, anti-corrosive aluminum radiator

Rugged steel-pressed engine cover

Safety

Gate lock system as standard equipment is designed to block up all operations

NEW

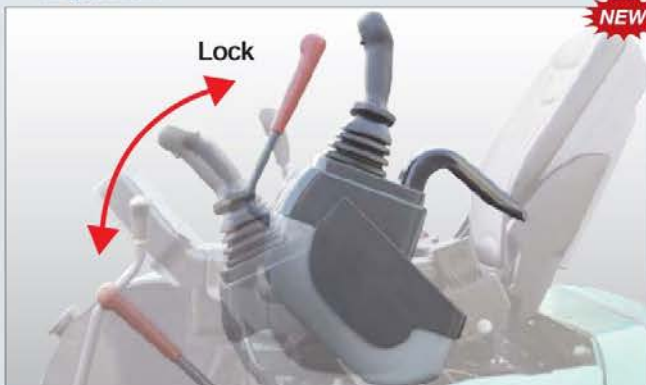

The master gate lock system enables you to block up all functions such as boom, arm, bucket, swing, boom swing, travel and blade.

4-Post canopy (ROPS) as standard equipment



Neutral engine start system.

The engine can start when the gate-lock is pulled up to avoid mis-operations.

Swing motor with auto parking brake

Featuring swing motor with an auto parking brake, the machine can be swung and locked at any position within a 360° circumference.

The unique spanner design in its class. Balanced transport-ability and work-stability.

 Assurance that IHI excavators are environment-conscious.

Operability

■ Newly designed operator's space



The new cockpit ensures safe and comfortable operations.

* See Page 26 for details.

■ With the widest spanner in its class, stability and performance in tight job sites are well-balanced.



Due to the unique design, the crawler width ranges from 1520mm to 1800mm, which enables to transport easily and to fit into tight work sites. This also provides outstanding balance and stability yet in wider work sites.

■ Close distance between bucket and blade



■ Additional auxiliary hydraulic lines (optional)

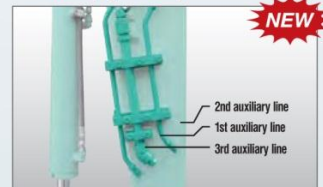

* See Page 27 for details.

Easy Maintenance

■ Segmented blade cylinder hose design makes replacement easier



■ Segmented boom cylinder hose design makes replacement easier



■ Easy accessible tool box



■ Wide, fully opening engine-cover enables ease of maintenance



- Filters are conveniently located, making it easy to replace them
- Sintered bushes create longer interval for greasing

35VX3 Mini Excavator

Standard Bucket Capacity : ISO 0.11m³



■ Dimensions (Unit:mm)

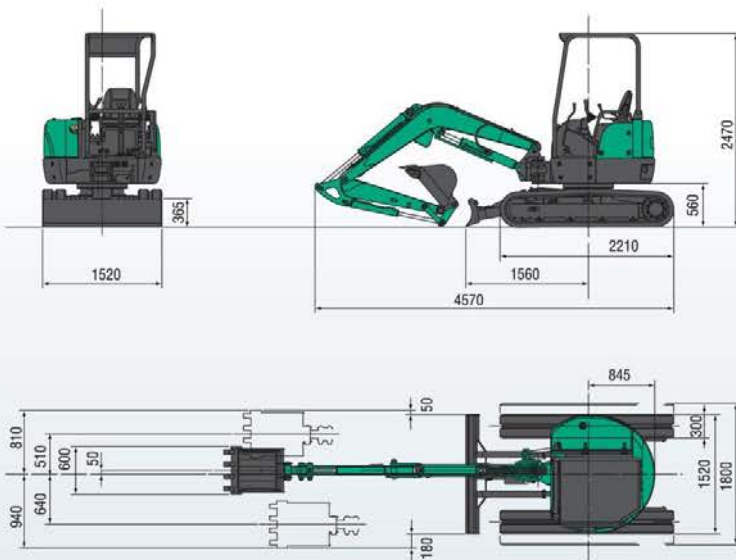

■ Working Range (Unit:mm)

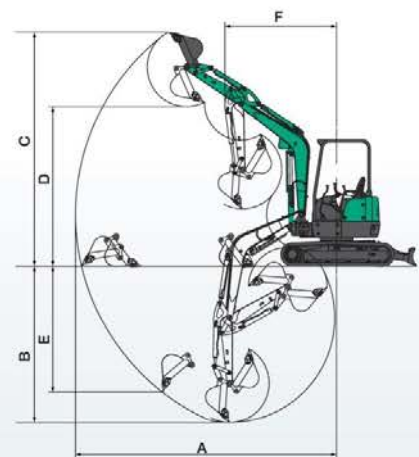

	4-Post or Cabin	2-Post canopy
A Max. digging radius	5090 (5410)	5090 (5410)
B Max. digging depth	3150 (3450)	3150 (3450)
C Max. digging height	4560 (4840)	5190 (5500)
D Max. dumping height	3120 (3370)	3670 (3970)
E Max. vertical digging depth	2500 (2950)	2500 (2950)
F Min. front turning radius	2180 (2180)	1720 (1910)
At right boom swing	1730 (1730)	1350 (1520)

* () : Figures for long arm

■ 35VX3 Specifications

Performance		Boom swing system	
Bucket capacity	0.11m ³	Type	Boom offset with hydraulic cylinder
Bucket width	600mm	Swing angle (L/R)	90°/50°
Operating weight: Cabin (4-Post)	3405kg (3505kg)	Hydraulic system	
Transportation weight: Cabin (4-Post)	3330kg (3430kg)	Pressure	20.6MPa (210kgf/cm ²), 24.5MPa (250kgf/cm ²)
Swing speed	8.8min ⁻¹	Pump hydraulic flow	40.3L/min×2+24.6L/min
Travel speed (low/high)	2.8/4.8km/h	Dozer blade	
Gradeability	58%(30°)	Size	1520mm×365mm
Ground pressure	29kPa (0.29kgf/cm ²)	Lift above ground / Drop below ground	370mm/390mm
Max bucket digging force	26.5kW (2700kgf)	Max auxiliary flow	
Engine		1st line	63L/min
Model	YANMAR 3TNV88	2nd line	24L/min
Rated output	20.3kW/2300min ⁻¹ (27.6PS/2300rpm)		
Fuel tank capacity	35L		

■ Options

Bucket

- 0.055m³/Digging bucket (400mm width)
- 0.08m³/Long arm bucket (500mm width)
- 0.12m³/Loading bucket (660mm width)

- 1st auxiliary piping
- 2nd auxiliary piping
- 3rd auxiliary piping
- 2-Post canopy
- Steel cabin

- Long arm (standard +300mm)
- Steel shoe (300mm)
- Rubber pad for steel shoe
- Slide arm

